

Sheridan Sanitation District No. 2

8390 E. Crescent Pkwy., Ste. 300
Greenwood Village, CO 80111
(303) 779-5710

Sanitary Sewer Service Connection / Tap Permit Application

DATE: _____

PROPERTY ADDRESS: _____

PROPERTY OWNER'S NAME (Applicant): _____

MAILING ADDRESS: _____

PHONE NUMBER: _____

PROPOSED CONNECTION / TAP TYPE: (check one)

- Single Family Residential
- Accessory Dwelling Unit (ADU)
- Other Than Single Family Residential (Commercial)

I certify that I own the property at the above listed property (service) address and agree to provide the Sheridan Sanitation District #2 (District) all necessary information, plans and/or records to correctly calculate the connection/tap fee. The sewer connection charge (connection/tap fee) will be based on current rates established by the District.

In addition, I agree to:

1. Submit full payment of the sewer connection charge to the District prior to connection to the District's main line.
2. Comply with all requirements of the District's Rules and Regulations.
3. Engage the services of a licensed plumber in the State of Colorado to perform the sewer service connection.
4. Notify the District of the date for the proposed connection (48 hours' prior notice). Allow a representative of the District to inspect and approve the plumbing connection at the District's system before the work is covered. The applicant agrees to uncover the service line connection should they fail to secure the inspection approval from a District representative.
5. Comply with all requirements of the City of Sheridan when working within their rights-of-way.
6. Agree to hold harmless the Sheridan Sanitation District #2, their Board of Directors and its contractors for any harm or unanticipated consequences arising from this request.

PLUMBER/PLUMBING COMPANY: _____

COMPANY ADDRESS: _____

COMPANY PHONE NUMBER: _____

Applicant's Signature: _____ Date: _____

Printed Name: _____

Return completed form to Nic Carlson (SSD#2 Manager) at Nicholas.Carlson@clacconnect.com

DISTRICT USE BELOW

Connection Inspection Date: _____ Inspected by: _____
(Approval to cover the lines is granted with approval of the inspection)

Amount of payment received by SSD#2: _____ SSD#2 Rep: _____

RECEIVED AUG 14 1985

EXHIBIT A

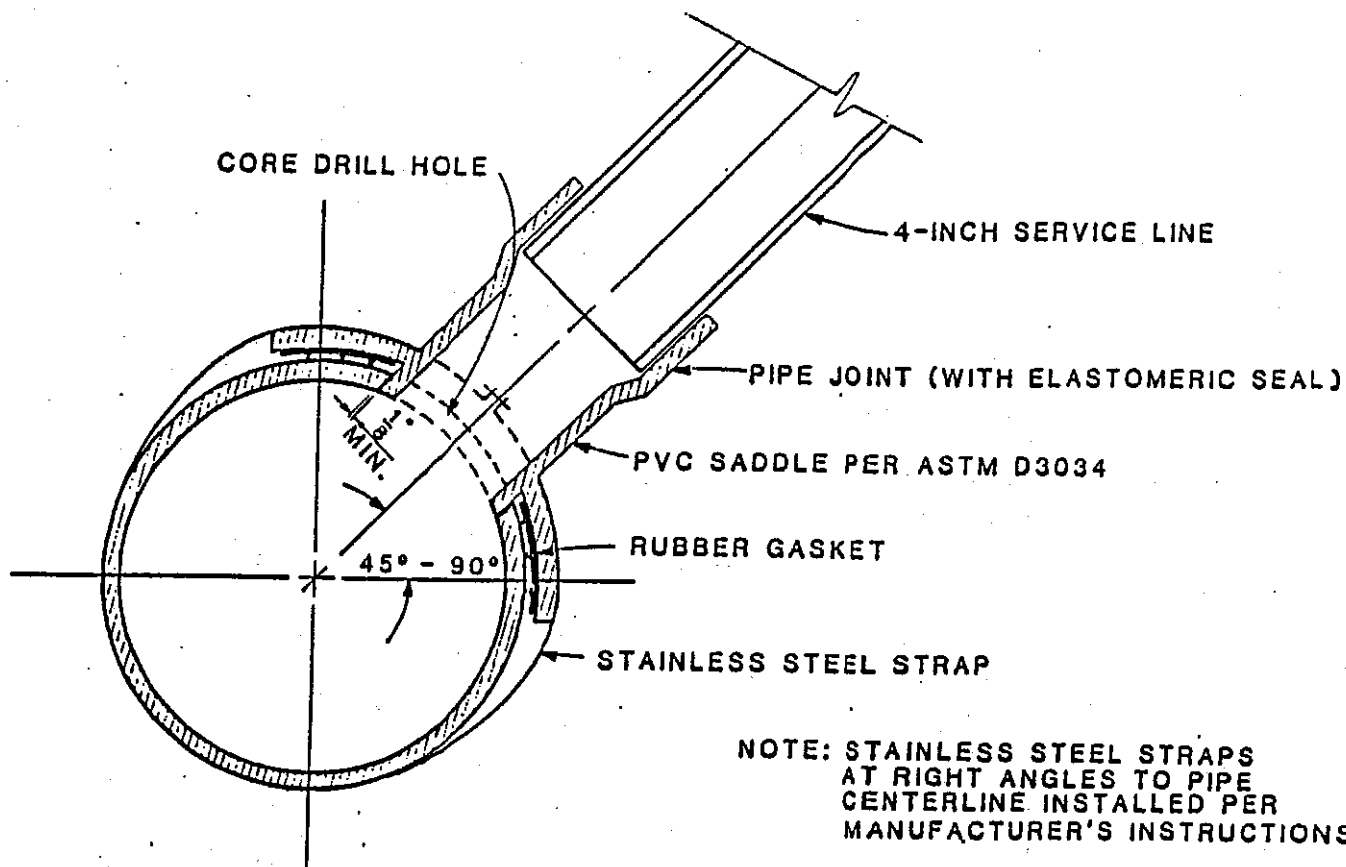

NOTE: THE PVC SADDLE MUST BE FASTENED
TO THE MAIN USING EPOXY IN ADDITION
TO THE STEEL STRAPS.

CONNECTIONS WITHOUT MANHOLE

N.T.S.